

PARTS

★製品改良のためキットは予告なく仕様を変更することがあります。
 ★Specifications are subject to change without notice.
 ★Technische Daten können im Zuge ohne Ankündigung verändert werden.
 ★Caractéristiques pouvant être modifiées sans information préalable.

A PARTS ×2 51112

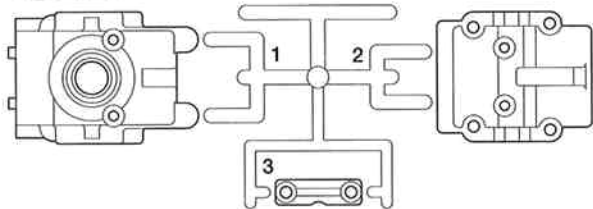

不要部品
 Not used.
 Nicht verwenden.
 Non utilisées.

B PARTS ×2 51113

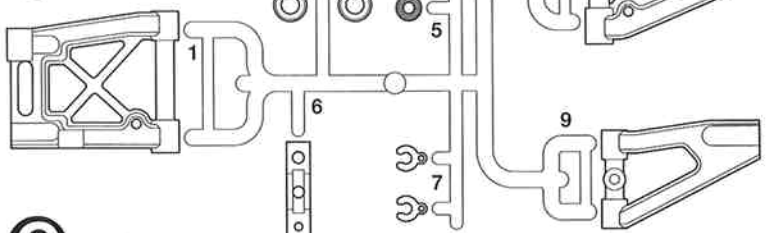

C PARTS ×1 51114

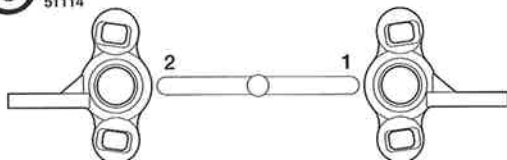

ロワデッキ……………×1
 Lower deck 51123
 Chassisboden
 Châssis inférieur

ホイール……………×4
 Wheel 9334092
 Rad
 Roue

J PARTS ×1 51117

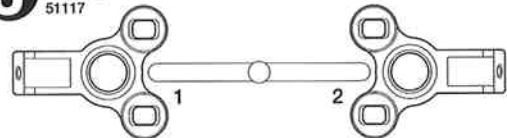

タイヤ
 (インナー スポンジ付) …×4
 Tire (with inner sponge) 51049
 Reifen (mit innerem Schaumgumming)
 Pneu (avec éponge intérieure)

ウレタンバンパー……………×1
 Urethane bumper 51124
 Urethan-Stoßfänger
 Pare-chocs en mousse

D PARTS ×1 51115

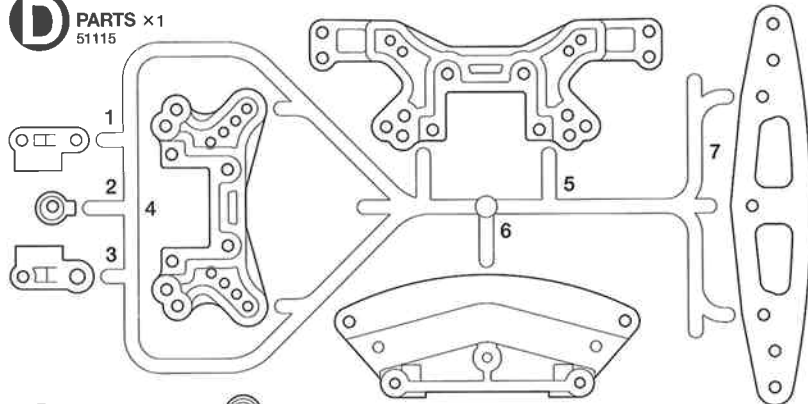

燃料タンク……………×1
 Fuel tank 41072
 Kraftstofftank
 Réservoir

燃料パイプ(シリコン) …×1
 Silicone tube 41053
 Silikon-Schlauch
 Durite silicone

アンテナパイプ……………×1
 Antenna pipe 6095010
 Antennenrohr
 Gaine d'antenne

ステッカー……………×1
 Sticker 9494078
 Aufkleber
 Autocollant

E PARTS ×1 0004247

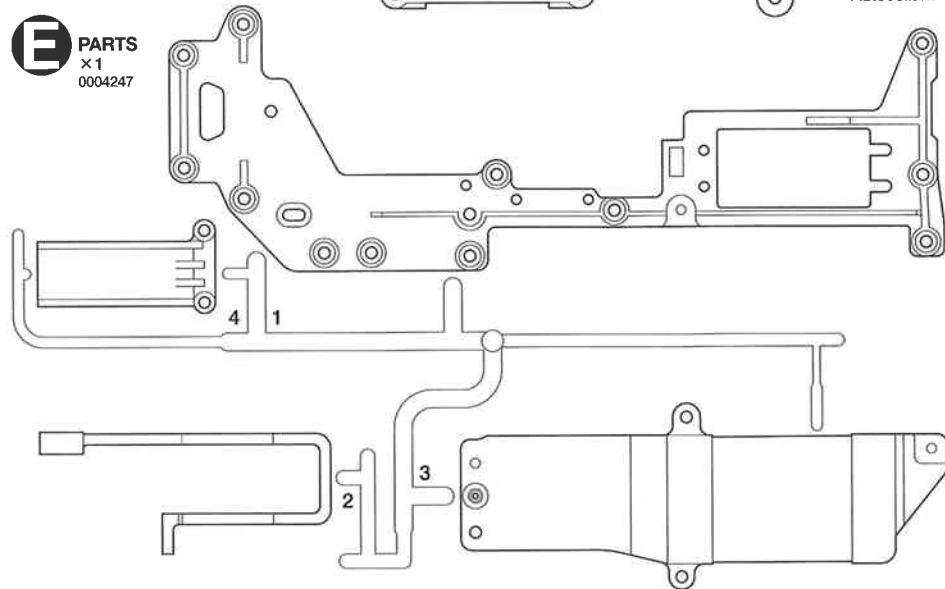

F PARTS ×1 0004248

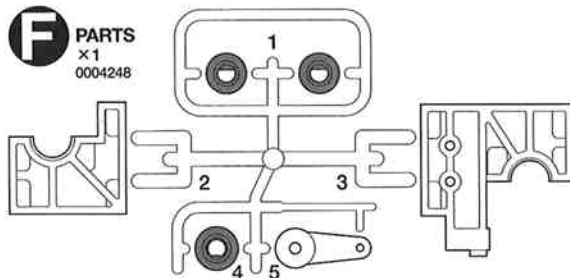

G PARTS ×2 51116

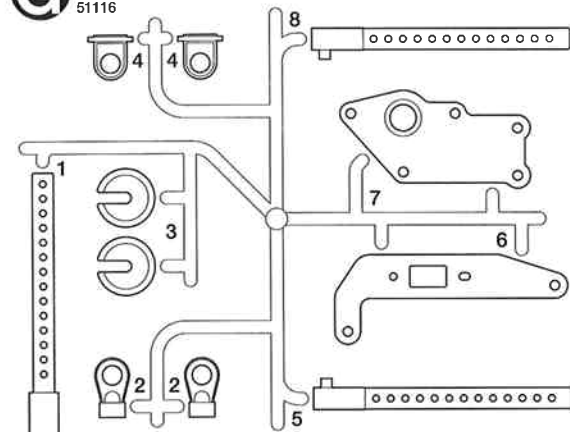

K PARTS ×1 51118

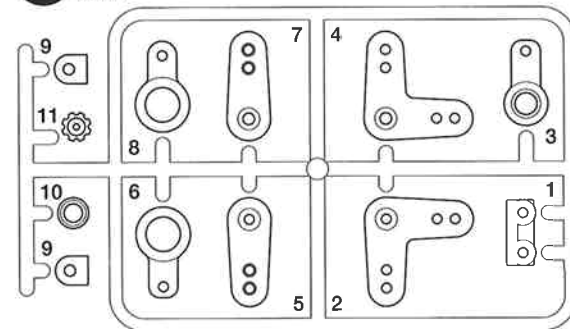

N PARTS ×2 51119

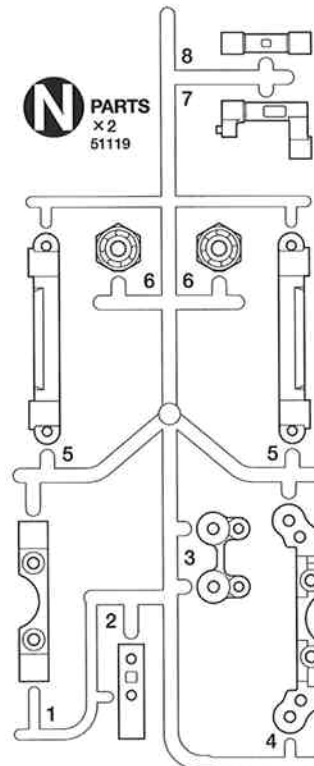

★金具部品は少し多目に入っています。
 予備、セッティング用として使ってください。
 ★Extra screws and nuts are included. Use them as spares.
 ★Es liegen zusätzliche Schrauben und -muttern bei. Als Ersatzteile verwenden.
 ★Des vis et des écrous supplémentaires sont inclus. Les utiliser comme pièces de rechange.

デフケース袋詰
Differential case bag
Differential-Gehäuse-Beutel
Sachet de carter de différentiel

デフケース.....×2
Differential case 51121
Differential-Gehäuse
Carter de différentiel

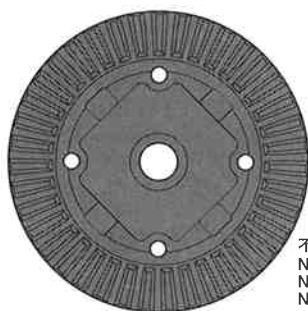

不要部品
Not used.
Nicht verwenden.
Non utilisée.

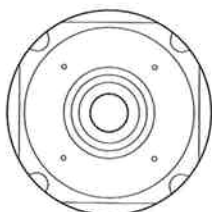

不要部品
Not used.
Nicht verwenden.
Non utilisée.

ギヤ袋詰 / Gear bag
Zahnräder-Beutel / Sachet de pignonnerie

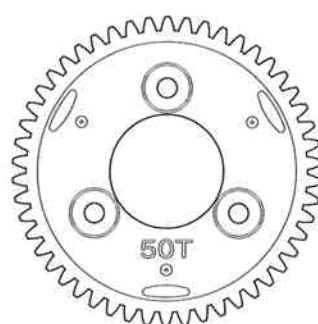

50Tスパークギヤ.....×1
Spur gear 51120
Stirnradgetriebe
Pignon intermédiaire

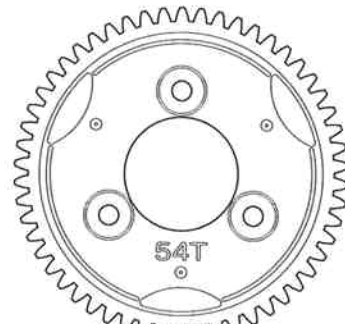

54Tスパークギヤ.....×1
Spur gear 51120
Stirnradgetriebe
Pignon intermédiaire

A 1~9

MA1 ×2
9805958
3×14mm六角丸ビス
Screw
Schraube
Vis

MA2 ×6
9805763
3×10mm六角丸ビス
Screw
Schraube
Vis

MA3 ×1
9805765
3×8mm六角丸ビス
Screw
Schraube
Vis

MA4 ×7
9805957
3×10mm六角皿ビス
Screw
Schraube
Vis

MA5 ×10
9805767
3×8mm六角皿ビス
Screw
Schraube
Vis

MA6 ×6
9804210
3×6mm六角皿ビス
Screw
Schraube
Vis

MA7 ×4
9804194
3×10mmホロービス
Screw
Schraube
Vis

MA8 ×4
9804204
4×4mmイモネジ
Grub screw
Madenschraube
Vis pointeau

MA9 ×2
53640
5mmビローボールナット
Ball connector nut
Kugelpf-Mutter
Ecrou-connecteur à rotule

MA10 ×2
53065
1260ベアリング
Ball bearing
Kugellager
Roulement à billes

MA11 ×1
50589
5mmEリング
E-Ring
Circlip

MA12 ×3
50594
2×10mmシャフト
Shaft
Achse
Axe

MA13 ×2
9804216
2.5×12mmキャップスクリュー
Cap screw
Zylinderkopfschraube
Vis à tête cylindrique

MA14 ×2
51141
3mmスチールボール
Steel ball
Stahlkugel
Bille en acier

MA15 ×2
51141
2スピードスプリングカラー
2-speed spring collar
2-Gang-Federhülse
Bague de ressort de boîte à 2 rapports

MA16 ×2
51141
2スピードスプリング
2-speed spring
2-Gang-Feder
Ressort de boîte à 2 rapports

MA17 ×1
3454298
2スピードシャフトスペーサー
2-speed shaft spacer
Distanzring der 2-Gang-Achse
Entretoise d'axe de boîte à 2 rapports

MA18 ×1
3454296
メインカム
Main cam
Hauptnocken
Came principale

MA19 ×1
51142
ミッションジョイントカップ
Transmission joint cup
Getriebe-Gelenkkapsel
Noix de transmission

MA20 ×1
51142
ブレーキジョイントカップ
Brake joint cup
Brems-Gelenkkapsel
Noix de frein

MA21 ×2
9804211
ステアリングポスト
Steering post
Lagerzapfen der Lenkung
Colonnnette de direction

MA22 ×1
3454292
ブレーキシャフト
Brake shaft
Bremsachse
Axe de frein



MA23 ×1
3454291
2スピードメインシャフト
2-speed main shaft
2-Gang-Hauptwelle
Axe principale de boîte à 2 rapports

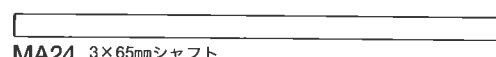

MA24 ×2
51122
3×65mmシャフト
Shaft
Achse
Axe

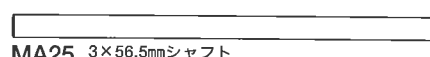

MA25 ×2
51122
3×56.5mmシャフト
Shaft
Achse
Axe

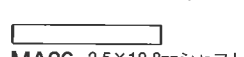

MA26 ×2
9804217
2.5×19.8mmシャフト
Shaft
Achse
Axe

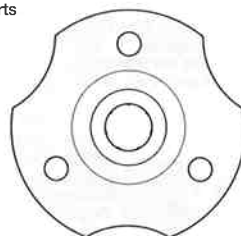

MA27 ×1
3454288
スパークホルダー(1速)
Spur holder (1st gear)
Stirnradhalterung (1. Gang)
Support de pignon intermédiaire (1^{re} vitesse)

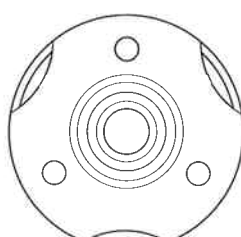

MA28 ×1
3454290
スパークホルダー(2速)
Spur holder (2nd gear)
Stirnradhalterung (2. Gang)
Support de pignon intermédiaire (2^{de} vitesse)

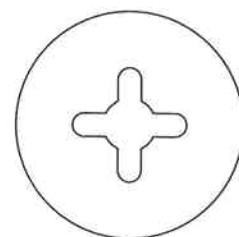

MA29 ×2
9804209
ブレーキディスク
Brake disc
Bremscheibe
Disque de frein

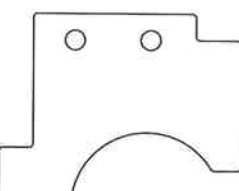

MA30 ×2
51140
ブレーキパッド(シルバー)
Brake pad (silver)
Bremsplatte (silver)
Plaquette de frein (chromée)

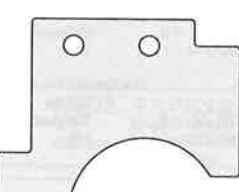

MA31 ×2
51140
ブレーキパッド
Brake pad
Bremsplatte
Plaquette de frein

B 10~17

MB1 ×4
9805778
3×12mm六角丸ビス
Screw
Schraube
Vis

MA2 ×2
9805763
3×10mm六角丸ビス
Screw
Schraube
Vis

MA3 ×11
9805765
3×8mm六角丸ビス
Screw
Schraube
Vis

MA4 ×4
9805957
3×10mm六角皿ビス
Screw
Schraube
Vis

MA5 ×10
9805767
3×8mm六角皿ビス
Screw
Schraube
Vis

MB2 ×8
50574
2×8mmタッピングビス
Tapping screw
Schneidschraube
Vis taraudeuse

MA8 ×2
9804204
4×4mmイモネジ
Grub screw
Madenschraube
Vis pointeau

MB3 ×2
50576
3mmイモネジ
Grub screw
Madenschraube
Vis pointeau











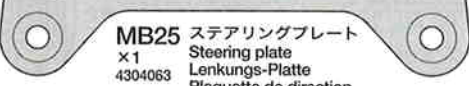
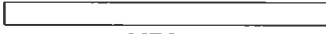
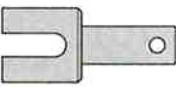
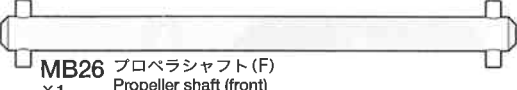
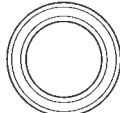

MB4 ×5
51131
6×7mmボールナット
Ball nut
Kugelmutter
Ecrou à rotule

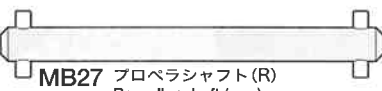
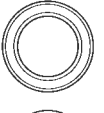
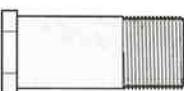
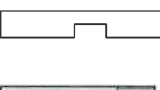
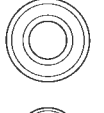
MB5 ×2
9805780
3×23mmターンバックルシャフト
Turn-buckle shaft
Spann-Achse
Biellette à pas inversés

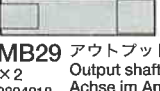
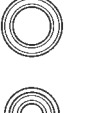
MB6 ×4
50953
6mmアジャスター
Adjuster
Einstellstück
Chape à rotule

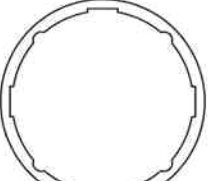
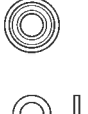

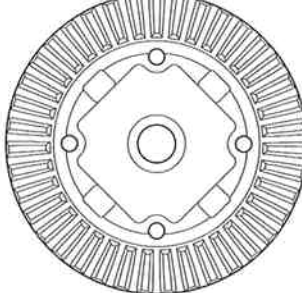

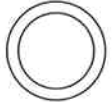
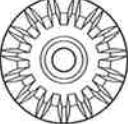





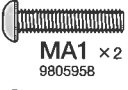



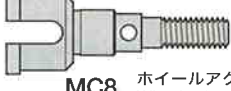
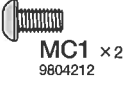

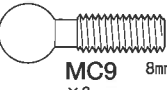
B

デフオイル.....×1
 Differential oil 53759
 Differential-Öl
 Huile de différentiel



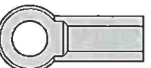

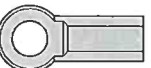
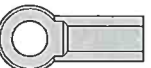





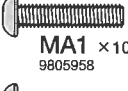

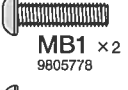

	MB7 ×4 9805776	2×9.8mmシャフト Shaft Achse Axe		MB16 ×4 9804219	5mmOリング(薄) O-ring (thin) O-Ring (dünn) Joint torique (fin)		MB25 ステアリングプレート Steering plate Lenkungs-Platte Plaque de direction
	MB8 ×2 51122	3×43mmシャフト Shaft Achse Axe		MB17 ×4 51146	デフジョイントカップ Differential joint cup Differential-Gelenkkapsel Noix de différentiel		MB26 プロペラシャフト(F) Propeller shaft (front) Antriebswelle (vorne) Arbre de transmission (avant)
	MB9 ×4 53126	1510ベアリング Ball bearing Kugellager Roulement à billes		MB18 ×2 51147	プロペラジョイントカップ Propeller joint cup Antriebs-Gelenkkapsel Noix d'arbre de transmission		MB27 プロペラシャフト(R) Propeller shaft (rear) Antriebswelle (hinten) Arbre de transmission (arrière)
	MB10 ×2 53066	1280ベアリング Ball bearing Kugellager Roulement à billes		MB19 ×1 51149	サーボセイバーポスト Servo saver post Servo-Saver-Stange Mât de sauve-servo		MB28 ベベルデフアクスル Differential axle Differential-Achse Axe de différentiel
	MB11 ×2 53008	1150ベアリング Ball bearing Kugellager Roulement à billes		MB20 ×1 51149	サーボセイバースプリングナット Servo saver nut Servo-Saver-Mutter Ecrou de sauve-servo		MB29 アウトプットシャフト Output shaft Achse im Antrieb Axe de sortie
	MB12 ×2 53030	850ベアリング Ball bearing Kugellager Roulement à billes		MB21 ×1 51149	サーボセイバースプリング Servo saver spring Servo-Saver-Feder Ressort de sauve-servo		MB30 デフケースバッキン Differential case gasket Differentialgehäuse-Dichtung Joint de carter de différentiel
	MB13 ×2 9805646	630フランジベアリング Flanged ball bearing Flansch-Kugellager Roulement à flasque		MB22 ×4 51144	ベベルギヤ(大) Large bevel gear Kegelrad groß Grand pignon conique		MB31 リングギヤ Ring gear Tellerad Couronne
	MB14 ×2 9805645	3×0.7mmスパーサー Spacer Distanzring Entretoise		MB23 ×8 51144	ベベルギヤ(小) Small bevel gear Kegelrad klein Petit pignon conique		
	MB15 ×4 53588	10×0.1mmシム Shim Scheibe Cale		MB24 ×2 51143	15Tベベルピニオン Bevel pinion gear Kegelritzel Pignon conique		

C 18~22

リヤスタビライザー.....×1
 Rear stabilizer 53739
 Hinterer Stabilisator
 Barre anti-roulis arrière

	MA1 ×2 9805958	3×14mm六角丸ビス Screw Schraube Vis		MB3 3mmイモネジ Grub screw Madenschraube Vis pointeau		MC7 ドライブシャフト Drive shaft Achswelle Arbre d'entraînement
	MA2 ×4 9805763	3×10mm六角丸ビス Screw Schraube Vis		MB5 3×23mmターンバックルシャフト Turn-buckle shaft Spann-Achse Biellette à pas inversés		MC8 ホイールアクスル Wheel axle Rad-Achse Axe de roue
	MC1 ×2 9804212	3×6mm六角丸ビス Screw Schraube Vis		MC3 3mmOリング(黒) O-ring (black) O-Ring (schwarz) Joint torique (noir)		MC9 8mmサスポール Suspension ball Aufhängungs-Kugel Rotule de suspension
	MC2 ×2 9804213	3×6mmホロービス Screw Schraube Vis		MB9 1510ベアリング Ball bearing Kugellager Roulement à billes		MC10 10mmアジャストナット Adjusting nut Einstellmutter Ecrou de réglage
				MC4 スタビエンド Stabilizer end Stabilisator-Endstück Extrémité de barre anti-roulis		MC5 6×7mmボールカラー Ball collar Kugelhülse Bague de rotule
				MB4 6×7mmボールナット Ball nut Kugelmutter Ecrou à rotule		MC6 6mmアジャスター Adjuster Einstellstück Chape à rotule
				MC5 6×7mmボールカラー Ball collar Kugelhülse Bague de rotule		MC6 5mmアジャスター-S Adjuster (short) Einstellstück (kurz) Chape à rotule (courte)
				MB6 6mmアジャスター Adjuster Einstellstück Chape à rotule		
				MC6 5mmアジャスター-S Adjuster (short) Einstellstück (kurz) Chape à rotule (courte)		

D 23~31

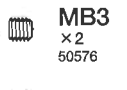
	MA1 ×10 9805958	3×14mm六角丸ビス Screw Schraube Vis		MA3 ×7 9805765	3×8mm六角丸ビス Screw Schraube Vis		MD7 3mmワッシャー Washer Beilagscheibe Rondelle
	MB1 ×2 9805778	3×12mm六角丸ビス Screw Schraube Vis		MD1 ×2 9805853	3×8mm丸ビス Screw Schraube Vis		MD8 2mmEリング E-Ring Circlip
	MA2 ×17 9805763	3×10mm六角丸ビス Screw Schraube Vis		MA5 ×3 9805767	3×8mm六角皿ビス Screw Schraube Vis		MB4 6×7mmボールナット Ball nut Kugelmutter Ecrou à rotule
				MD2 ×2 9804220	2.6×8mm丸ビス Screw Schraube Vis		MC5 6×7mmボールカラー Ball collar Kugelhülse Bague de rotule
				MD3 ×2 9805868	2×10mm丸ビス Screw Schraube Vis		MD6 3mmロックナット Lock nut Sicherungsmutter Ecrou nylstop
				MD4 ×2 9805754	3×8mmタッピングビス Tapping screw Schneidschraube Vis taraudeuse		MB12 850ベアリング Ball bearing Kugellager Roulement à billes
				MD5 ×2 9805911	2.6×8mmタッピングビス Tapping screw Schneidschraube Vis taraudeuse		
				MB3 ×2 50576	3mmイモネジ Grub screw Madenschraube Vis pointeau		

D

<p>MD9 ×2 9804221</p> <p>ロッドストッパー Rod stopper Gestänge-Stellring Bague de renvoi</p>	<p>MD13 ブレーキロッド ×1 2924002</p> <p>ブレーキロッド Brake rod Bremsgestänge Commande de frein</p>	<p>MD18 オイルシール ×4 53576</p> <p>オイルシール Oil seal Ölabdichtung Joint d'étanchéité</p>	<p>MD23 ダンパーシリンダー ×4 9804214</p> <p>ダンパーシリンダー Damper cylinder Dämpfer-Zylinder Corps d'amortisseur</p>
<p>MD10 ×1 5004027</p> <p>スロットルスプリング Throttle spring Gasfeder Ressort des gaz</p>	<p>MD14 ×1 2924001</p> <p>スロットルロッド Throttle rod Gasgestänge Commande des gaz</p>	<p>MD19 ×4 9805504</p> <p>ピストンロッド Piston rod Kolbenstange Axe de piston</p>	<p>MD24 ×2 53754</p> <p>コイルスプリング Coil spring Spiralfeder Ressort hélicoïdal</p>
<p>MD11 ×1 0445563</p> <p>4mmアジャスター Adjuster Einstellstück Chape à rotule</p>	<p>MD15 ×12 9804165</p> <p>サーボグロメット Servo grommet Servo-Muffe Coussinet de servo</p>	<p>MD20 ×4 53573</p> <p>ピストン Piston Kolben</p>	<p>MD25 ×2 53749</p> <p>コイルスプリング (ショート) Coil spring (short) Spiralfeder (kurz) Ressort hélicoïdal (court)</p>
<p>MD12 ×1 9805698</p> <p>3×28mmターンバックルシャフト Turn-buckle shaft Spann-Achse Biellette à pas inversés</p>	<p>MD16 ×4 9804222</p> <p>スプリングリテーナー(A) Spring retainer (A) Feder-Spanner (A) Butée de ressort (A)</p>	<p>MD21 ×4 53574</p> <p>ロッドガイド Rod guide Stangenführung Guide d'axe</p>	<p>MD22 ×8 53574</p> <p>3mm Oリング(シリコン) Silicone O-ring Silikon-O-Ring Joint silicone</p>
	<p>MD17 ×4 9804223</p> <p>スプリングリテーナー(B) Spring retainer (B) Feder-Spanner (B) Butée de ressort (B)</p>		<p>ダンパーオイル.....×1 Damper oil Dämpfer-Öl Huile pour amortisseurs 53443</p>

E 32 ~ 42

<p>MB1 ×2 9805778</p> <p>3×12mm六角丸ビス Screw Schraube Vis</p>	<p>ME6 ×12 51139</p> <p>5×0.1mmシム Shim Scheibe Cale</p>	<p>ME15 ×1 51134</p> <p>クラッチスプリングアダプター Clutch spring adapter Kupplungsfeder-Adapter Adaptateur de ressort d'embrayage</p>	<p>ME21 ×4 51136</p> <p>クラッチウエイト Clutch weight Kupplungsgewicht Lest d'embrayage</p>
<p>MA2 ×8 9805763</p> <p>3×10mm六角丸ビス Screw Schraube Vis</p>	<p>ME7 ×1 53587</p> <p>5×0.2mmシム Shim Scheibe Cale</p>	<p>ME16 ×1 51133</p> <p>テーパコレット Taper collet Spannkonus Cône</p>	
<p>MA3 ×2 9805765</p> <p>3×8mm六角丸ビス Screw Schraube Vis</p>	<p>MA10 ×4 53065</p> <p>1260ベアリング Ball bearing Kugellager Roulement à billes</p>	<p>ME17 ×1 51134</p> <p>フライホイールナット Flywheel nut Schwingscheibe-Mutter Ecrou de volant d'embrayage</p>	
<p>MA4 ×6 9805957</p> <p>3×10mm六角皿ビス Screw Schraube Vis</p>	<p>ME8 ×2 9805834</p> <p>1050ベアリング Ball bearing Kugellager Roulement à billes</p>	<p>ME18 ×1 51137</p> <p>クラッチベル Clutch bell Kupplungslocke Cloche d'embrayage</p>	<p>ME22 ×1 51133</p> <p>フライホイール Flywheel Schwingscheibe Volant d'embrayage</p>
<p>MA5 ×2 9805767</p> <p>3×8mm六角皿ビス Screw Schraube Vis</p>	<p>ME9 ×1 51138</p> <p>スラストワッシャー(A) Thrust washer (A) Druckscheibe (A) Rondelle de butée (A)</p>		<p>ME23 ×1 53730</p> <p>20Tピニオンギヤ 20T Pinion gear 20Z Motorritzel Pignon moteur 20 dents</p>
<p>ME1 ×1 9804224</p> <p>3×12mmキャップスクリュー Cap screw Zylinderkopfschraube Vis à tête cylindrique</p>	<p>ME10 ×1 51138</p> <p>スラストベアリング Ball thrust bearing Druckkugellager Butée à billes</p>		
<p>ME2 ×4 9805612</p> <p>3×10mmキャップスクリュー Cap screw Zylinderkopfschraube Vis à tête cylindrique</p>	<p>ME11 ×1 51138</p> <p>スラストワッシャー(B) Thrust washer (B) Druckscheibe (B) Rondelle de butée (B)</p>	<p>ME19 ×1 3454279</p> <p>クラッチディスク Clutch disc Kupplungsscheibe Disque d'embrayage</p>	
<p>ME3 ×4 9805557</p> <p>4mmフランジロックナット Flange lock nut Sicherungsmutter Ecrou nylstop à flasque</p>	<p>MA12 ×4 50594</p> <p>2×10mmシャフト Shaft Achse Axe</p>		
<p>MD6 ×1 2220001</p> <p>3mmロックナット Lock nut Sicherungsmutter Ecrou nylstop</p>	<p>ME12 ×1 3454284</p> <p>スラストベアリングホルダー Ball thrust bearing holder Druckkugellager-Halter Support de butée à billes</p>	<p>ME20 ×1 51135</p> <p>クラッチシュー Clutch shoe Kupplungs-Backen Masselotte d'embrayage</p>	<p>ME24 ×1 53733</p> <p>24Tピニオンギヤ 24T Pinion gear 24Z Motorritzel Pignon moteur 24 dents</p>
<p>ME4 ×4 9805705</p> <p>3mm皿ワッシャー Washer Beilagscheibe Rondelle</p>	<p>ME13 ×1 53736</p> <p>クラッチスプリング Clutch spring Kupplungsfeder Ressort d'embrayage</p>		
<p>ME5 ×2 50597</p> <p>3mm Oリング(赤) O-ring (red) O-Ring (rot) Joint torique (rouge)</p>	<p>ME14 ×1 51134</p> <p>クラッチスプリングナット Clutch spring nut Kupplungsfeder-Mutter Ecrou de ressort d'embrayage</p>		<p>ME25 ×2 9804215</p> <p>エンジンマウント Engine mount Motor-Halterung Bâti-moteur</p>
			<p>ME26 ×1 5220009</p> <p>マフラスター Muffler stay Schalldämpfer-Halter Support de silencieux</p>

工具袋詰

Tool bag
Werkzeug-Beutel
Sachet d'outillage
9404528



MT1 ×8
9805702

6mmスナップピン
Snap pin
Federstift
Epingle métallique

ゴムバンド ×1
Rubber band 9804142
Gummiband
Bande caoutchouc

アンチウェアグリス ×1
Anti-wear grease 53439
Verschleißf mindermendes Fett
Graisse anti-usure

セラミックグリス ×1
Ceramic grease 87025
Keramikfett
Graisse céramique

板レンチ ×1
Wrench 4305026
Mutternschlüssel
Clé

十字レンチ ×1
Box wrench 5494014
Steckschlüssel
Clé à tube

六角棒レンチ (2.5mm) ×1
Hex wrench (2.5mm) 50038
Imbusschlüssel (2,5mm)
Clé Allen (2,5mm)

六角棒レンチ (2mm) ×1
Hex wrench (2mm) 2990027
Imbusschlüssel (2mm)
Clé Allen (2mm)

六角棒レンチ (1.5mm) ×1
Hex wrench (1.5mm) 50038
Imbusschlüssel (1,5mm)
Clé Allen (1,5mm)

両面テープ ×1
Double-sided tape 50171
Doppelklebeband
Adhésif double face

ナイロンバンド ×3
Nylon band 50595
Nylonband
Collier en nylon

六角棒レンチ (5mm) ×1
Hex wrench (5mm) 2990038
Imbusschlüssel (5mm)
Clé Allen (5mm)

AFTER MARKET SERVICE CARD

When purchasing Tamiya replacement parts, please take or send this form to your local Tamiya dealer so that the parts required can be correctly identified and supplied. Please note that specifications, availability and price are subject to change without notice.

KUNDENACHBETREUUNGS-KARTE

Wenn Sie TAMIYA-Ersatzteile kaufen möchten, nehmen Sie bitte zur Unterstützung dieses Formular mit zu Ihrem örtlichen Fachhändler. Bezüglich der Angaben, der Lagerhaltung der Artikel und der Preise sind Änderungen vorbehalten.

SERVICE APRES-VENTE

Liste de pieces detachées Afin de vous permettre de vous procurer des pieces de rechange Tamiya, amenez cette liste à votre point de vente Tamiya qui ne manquera pas de vous renseigner. Veuillez noter que les caractéristiques, disponibilité et prix peuvent changer sans avis préalable.

PARTS CODE

- 51123 TG10-Mk.2 Lower Deck
51112 *1 TG10-Mk.2 A Parts (Gear Case) (A1-A3, 1 pc.)
51113 *1 TG10-Mk.2 B Parts (Suspension Arm) (B1-B9, 1 pc.)
51114 TG10-Mk.2 C Parts (Front Upright) (C1 & C2)
51115 TG10-Mk.2 D Parts (Damper Stay) (D1-D7)
0004247 E Parts (E1-E4)
0004248 F Parts (F1-F5)
51116 *1 TG10-Mk.2 G Parts (Body Mount) (G1-G8, 1 pc.)
51117 TG10-Mk.2 J Parts (Rear Upright) (J1 & J2)
51118 TG10-Mk.2 K Parts (Steering Arm) (K1-K11)
51119 *1 TG10-Mk.2 N Parts (Suspension Mount) (N1-N8, 1 pc.)
51120 TG10-Mk.2 Spur Gear Set (50T, 54T)
51121 *1 TG10-Mk.2 Diff. Case (1 pc.)
51124 TG10-Mk.2 Urethane Bumper
41072 TG10-Mk.2 Fuel Tank (75cc)
41053 2x5mm Silicone Fuel Pipe (Blue, 1m)
9334092 Wheels (4 pcs.)
51049 *1 Medium-Narrow Racing Slicks (2 pcs.)
9805958 3x14mm Round Head Socket Screw (MA1 x10)
9805763 3x10mm Round Head Socket Screw (MA2 x10)
9805765 3x8mm Round Head Socket Screw (MA3 x10)
9805957 3x10mm Countersunk Hex Head Screw (MA4 x10)
9805767 3x8mm Countersunk Hex Head Screw (MA5 x10)
9804210 3x6mm Countersunk Hex Head Screw (MA6 x10)
9804194 *1 3x10mm Screw (MA7 x2)
9804204 4x4mm Grub Screw (MA8 x5)
53640 5mm Aluminum Ball Nut (Blue, MA9 x10)
53065 1260 Sealed Ball Bearing (MA10 x2)
50589 5mm E-ring (MA11 x5)
50594 2x10mm Shaft (MA12 x10)
51141 TG10-Mk.2 2-Speed Transmission Spring Set (MA13-MA16, 2 pcs. each)
9804216 2.5x12mm Cap Screw (MA13 x2)
345298 2-Speed Shaft Spacer (MA17)
3454296 Main Cam (MA18)
51142 TG10-Mk.2 Transmission & Brake Joint Cup Set (MA19 & MA20)
9804211 Steering Post (MA21 x2)
3454292 Brake Shaft (MA22)
3454291 2-Speed Main Shaft (MA23)
51122 TG10-Mk.2 Suspension Shaft Set (MA24, MA25, MB8, 2 pcs. each)
9804217 2.5x19.8mm Shaft (MA26 x2)
3454288 Spur Holder (1st Gear) (MA27)
3454290 Spur Holder (2nd Gear) (MA28)
9804209 Brake Disc (MA29 x2)

- 51140 TG10-Mk.2 Brake Pad Set (MA30 & MA31, 2 pcs. each)
9805778 3x12mm Round Head Socket Screw (MB1 x10)
50574 2x8mm Countersunk Tapping Screw (MB2 x10)
50576 3mm Grub Screw (MB3 x10)
51131 6x7mm Ball Nut (MB4 x4)
9805780 3x23mm Turnbuckle Shaft (MB5 x4)
50953 6mm Adjuster Set (MB6 x16)
9805776 2x9.8mm Shaft (MB7 x10)
51126 1510 Sealed Ball Bearing (MB9 x2)
53066 1280 Sealed Ball Bearing (MB10 x3)
53008 1150 Sealed Ball Bearing (MB11 x4)
53030 850 Sealed Ball Bearing (MB12 x4)
9805646 630 Flanged Ball Bearing (MB13 x2)
9805645 3x0.7mm Spacer (MB14 x10)
53588 10mm Shim Set (MB15 x10...etc.)
9804219 5mm O-ring (Thin) (MB16 x5)
51146 *1 TG10-Mk.2 Diff. Joint Cup (MB17 x2)
51147 TG10-Mk.2 Propeller Joint Cup (MB18 x2)
51149 TG10-Mk.2 Servo Saver Spring Set (MB19-MB21)
51144 *1 TG10-Mk.2 Diff. Bevel Gear Set (MB22 x2, MB23 x4, MB28 x2)
51143 *1 TG10-Mk.2 Ring Gear Set (MB24 & MB31, 1 pc. each)
4304063 Steering Plate (MB25)
51148 TG10-Mk.2 Propeller Shaft Set (F & R) (MB26 & MB27)
9804218 Output Shaft (MB29 x2)
51145 TG10-Mk.2 Diff. Case Packing (MB30 x4)
9804212 3x6mm Round Head Socket Screw (MC1 x10)
9804213 3x6mm Screw (MC2 x2)
9805240 3x0.7mm Ring (Black) (MC3 x7...etc.)
51132 6mm Aluminum Stabilizer End (MC4 x2)
51130 6x7mm Ball Collar (MC5 x4)
50797 5mm Short Adjuster (MC6 x8)
51127 *1 TG10-Mk.2 Drive Shaft (MC7 x2)
51126 *1 TG10-Mk.2 Wheel Axle (MC8 x2)
51128 *1 TG10-Mk.2 8mm Suspension Ball (MC9 x4)
51129 *1 TG10-Mk.2 10mm Adjuster Nut (MC10 x4)
9805853 3x8mm Screw (MD1 x5)
9804220 2.6x8mm Screw (MD2 x10)
9805868 2x10mm Screw (MD3 x10)
9805754 3x8mm Tapping Screw (MD4 x10)
9805911 2.6x8mm Tapping Screw (MD5 x10)
2220001 3mm Lock Nut (MD6 x1)
50586 3mm Washer (MD7 x15)
50588 2mm E-ring (MD8 x8)
9804221 Rod Stopper (MD9 x2)

- 5004027 Throttle Spring (MD10)
0445563 4mm Adjuster (MD11 x3)
9805698 3x28mm Turnbuckle Shaft (MD12 x2)
2924002 Brake Rod (MD13)
2924001 Throttle Rod (MD14)
9804165 Servo Grommet (MD15 x10)
9804222 Spring Retainer (A) (MD16 x4)
9804223 Spring Retainer (B) (MD17 x4)
53576 TRF Damper Oil Seal (MD18 x4)
9805504 *1 Piston Rod (MD19 x2)
53573 TRF Damper Piston (3-Hole, MD20 x4)
53574 TRF Damper Rod Guide & O-ring Set (MD21 & MD22, 4 pcs. each)
9804214 *1 Damper Cylinder (MD23 x2)
53754 GE Damper Spring (Medium) (MD24 x2)
53749 GE Short Damper Spring (Medium) (MD25 x2)
9804224 3x12mm Cap Screw (ME1 x2)
9805612 3x10mm Cap Screw (ME2 x5)
9805557 4mm Flange Lock Nut (ME3 x4)
9805705 3mm Washer (ME4 x6)
50597 Damper O-ring (Red) (ME5 x10)
51139 5x10x0.1mm Shim (ME6 x10)
53587 5mm Shim Set (ME7 x10...etc.)
9805834 1050 Ball Bearing (ME8 x2)
51138 1050 Trust Bearings (ME9-ME11)
3454284 Ball Thrust Bearing Holder (ME12)
53736 Racing Clutch Spring (Soft) (ME13)
51134 TG10-Mk.2 Flywheel Nut Set (ME14, ME15, ME17)
51133 Racing Clutch Flywheel w/Tapered Collet (ME16 & ME22)
51137 Racing Clutch Bell (ME18)
3454279 Clutch Disc (ME19)
51135 Racing Clutch Shoes (ME20)
51136 Racing Clutch Weight (ME21 x4)
53730 Racing Clutch Pinion Gear 20T (1st Gear) (ME23)
53733 Racing Clutch Pinion Gear 24T (2nd Gear) (ME24)
9804215 Engine Mount (ME25 x2)
5220009 Muffler Stay (ME26)
53739 TG10-Mk.2 Rear Stabilizer Rod Set
53759 Silicone Diff. Oil #10000
9404528 Tool Bag
9805702 6mm Snap Pin (MT1 x10)
6095010 Antenna Pipe (30cm) (Black)
9494078 Sticker
1054372 Instructions
*1 Requires 2 sets for one car.

★部品請求にはこのカードが必要です。

部品請求をなさる方はあなたの氏名、住所、郵便番号、電話番号をこのカードに記入してください。

1/10th GLOW-ENGINE R/C 4WD RACING CAR CHASSIS KIT



1/10 エンジンRC 4WDレーシングカー TG10-Mk.2シャーシキット

部品をなくしたり、こわした方は、下のステッカーが貼られたカスタマーサービス取次店でご注文いただけます。当社カスタマーサービスに直接ご注文する場合は、このカードの必要部品を○でかきこみ代金を現金書留または、定額小為替(100円以下は切手可)と一緒にお願いします。なお、ご送金にはタミヤカードや郵便振替もご利用いただけます。



Table with 2 columns: Part Name and Price. Includes items like Eパーツ, Fパーツ, ホール(4本), スーパーホルダー(1速), etc.

Table with 2 columns: Part Name and Price. Includes items like 3x10mm六角皿ビス(10本), 3x6mm六角皿ビス(10本), etc.

この他にも修理や整備のためのRCスベアパーツが発売されています。お近くの模型店店頭、または当社カスタマーサービスでお買い求めください。

Table with 2 columns: Part Name and Price. Includes items like ロワテック, Aワーツx1, Bワーツx1, etc.

Table with 2 columns: Part Name and Price. Includes items like スラストベアリング, 5x0.1mmシムx10, フレーキパッド, etc.

《お問い合わせ番号》 静岡 054-283-0003

営業時間 東京 03-3899-3765 (静岡へ自動転送) 平日(月~金曜日) 8:00~20:00 土、日、祝日 8:00~17:00

For Japanese use only! ITEM 44042

Address form with fields for 住所, 電話, 氏名.

★パーツの価格は予告なく変更となる場合があります。

