

PARTS

★製品改良のためキットは予告なく仕様を変更することがあります。
 ★Specifications are subject to change without notice.
 ★Technische Daten können im Zuge ohne Ankündigung verändert werden.
 ★Caractéristiques pouvant être modifiées sans information préalable.

A PARTS ×2
9005870

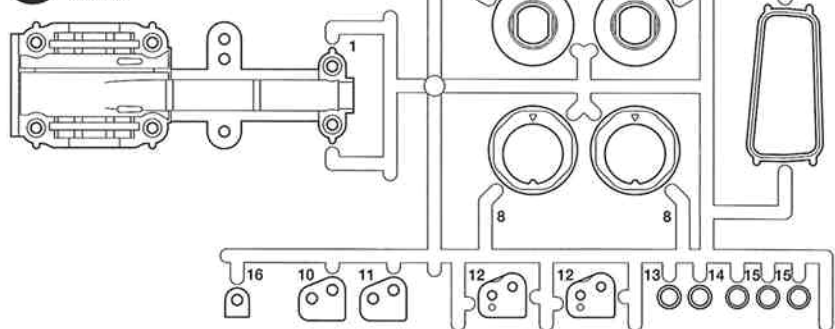

C PARTS ×1
51308

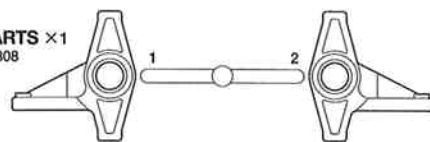

D PARTS ×1
51309



E PARTS ×1
51310



B PARTS ×1
51307

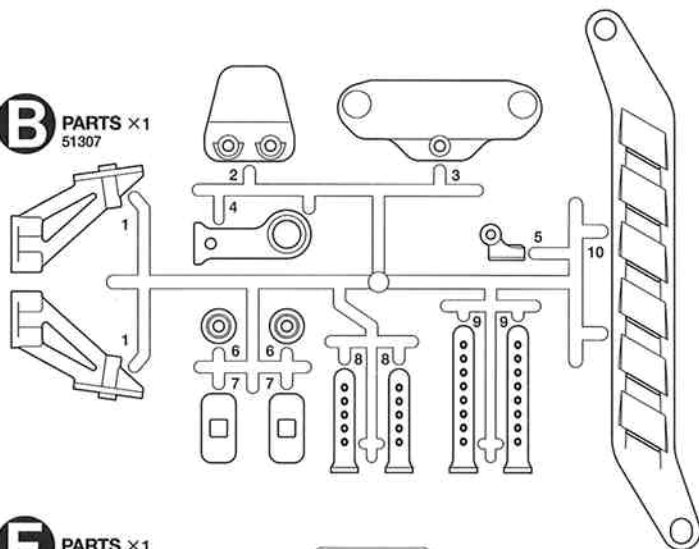

L PARTS ×1
9115202

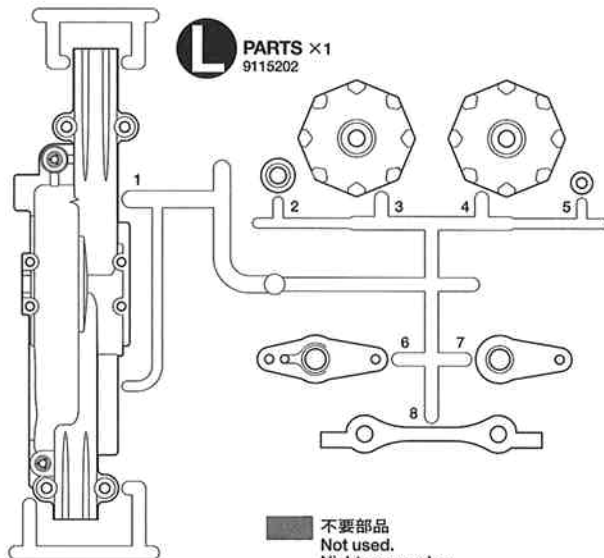

不要部品
Not used.
Nicht verwenden.
Non utilisées.

F PARTS ×1
51311

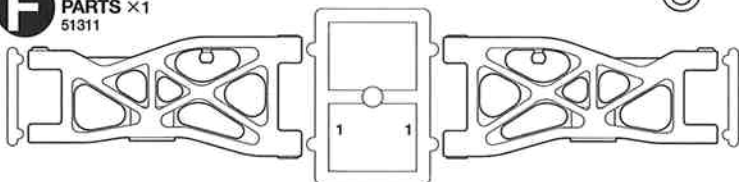

R PARTS ×1
51313

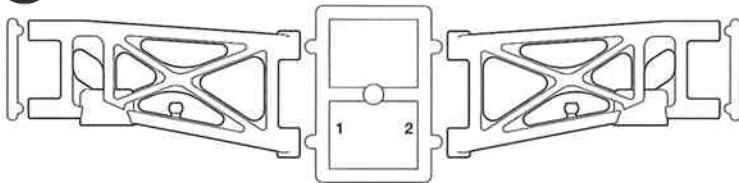

Q PARTS ×1
51000

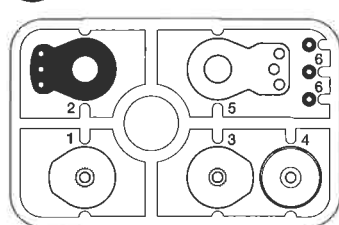

K PARTS ×2
9115204

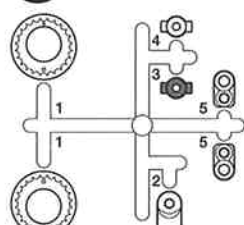

M PARTS ×1
51312

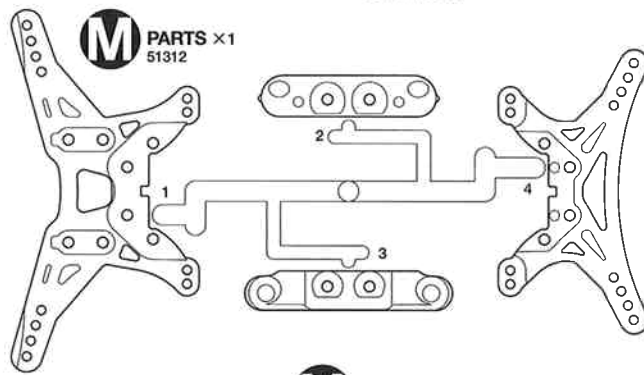

V PARTS ×2
50598

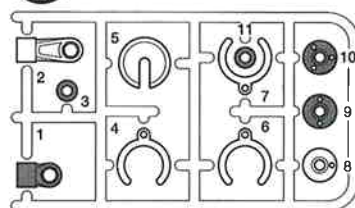

W PARTS ×2
50599

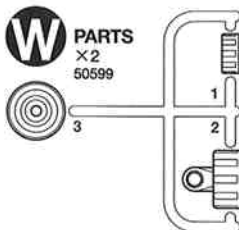

Y PARTS ×2
0225073

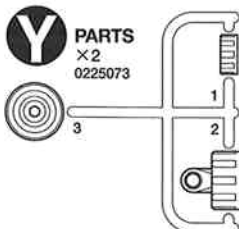

X PARTS ×2
50950

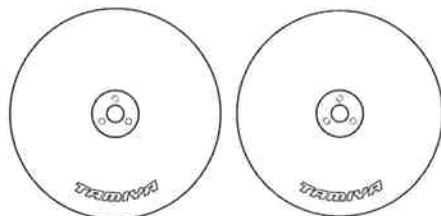
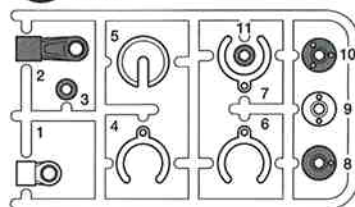

フロントホイール (細) ×2
Front wheel (narrow)
Vorderrad (schmal)
Roue avant (étroit)

リヤホイール (太) ×2
Rear wheel (wide)
Hinterrad (breit)
Roue arrière (large)

PARTS

シャーシ×1
Chassis 9335492
Châssis

フロントタイヤ (インナーフォーム付) ×2
Front tire
Vorderer Reifen
Pneu avant

アンテナパイプ×1
Antenna pipe 6095010
Antennenrohr
Gaine d'antenne

ベルト×2
Drive belt 53987
Antriebsriemen
Courroie

リアタイヤ (インナーフォーム付)×2
Rear tire
Hinterer Reifen
Pneu arrière

注意ステッカー×1
Caution sticker
Vorsicht Sticker
Sticker de precaution

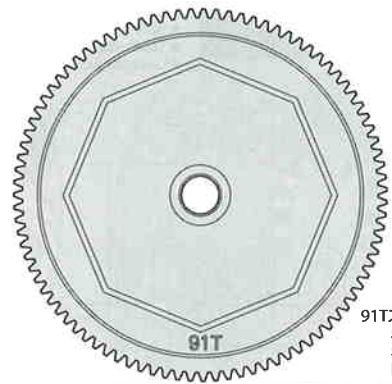

91Tスパーギヤ×1
Spur gear 51314
Stirnradgetriebe
Pignon intermédiaire

モーターマウント袋詰 9400669 Motor mount bag Motor-Lager Beutel Sachet de support-moteur

BM1 ×1 3×10mmホロービス
Screw
Schraube
Vis
9804194

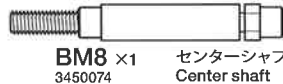

BM8 ×1 センターシャフト
Center shaft
Zentralwelle
Axe central
3450074

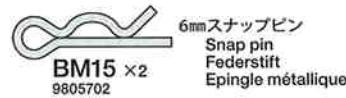

BM15 ×2 6mmスナップピン
Snap pin
Federstift
Epingle métallique
9805702



BM18 ×1 23Tピニオンギヤ
23T Pinion gear
23Z Motorritzel
Pignon moteur 23 dents
3514044

BM2 ×3 3mmロックナット
Lock nut
Sicherungsmutter
Ecrou nylstop
9805991

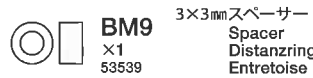

BM9 ×1 3×3mmスペーサー
Spacer
Distanzring
Entretoise
53539



BM16 ×2 51000 サーボセイバースプリング (小)
Servo saver spring (small)
Servo-Saver-Feder (klein)
Ressort de sauve-servo (petit)
51000

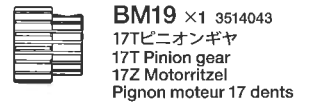

BM19 ×1 17Tピニオンギヤ
17T Pinion gear
17Z Motorritzel
Pignon moteur 17 dents
3514043

BM3 ×2 3mmワッシャー
Washer
Beilagscheibe
Rondelle
50586

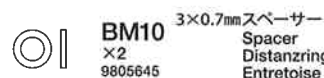

BM10 ×2 3×0.7mmスペーサー
Spacer
Distanzring
Entretoise
9805645



BM17 ×1 51000 サーボセイバースプリング (大)
Servo saver spring (large)
Servo-Saver-Feder (groß)
Ressort de sauve-servo (grand)
51000



BM20 18Tプーリー
Pulley
Rolle
Poulie
×2 53989

BM4 ×1 3mmEリング
E-Ring
Circlip
50380

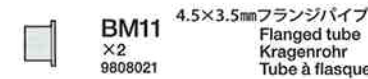

BM11 ×2 4.5×3.5mmフランジパイプ
Flanged tube
Kragenrohr
Tube à flasque
9808021

BM5 ×18 5mmピローボール
Ball connector
Kugelkopf
Connecteur à rotule
9804205



BM12 ×2 ステアリングポスト
Steering post
Lagerzapfen der Lenkung
Colonnettes de direction
9808151

BM6 ×1 5mmピローボールナット
Ball connector nut
Kugelkopf-Mutter
Ecrou-connecteur à rotule
9804206



BM13 ×8 ウレタンブッシュ (赤)
Urethane bushing (red)
Urethan-Buchse (rot)
Bague polyuréthane (rouge)
53577

BM7 ×1 5mmピローボールナット (短)
Ball connector nut (short)
Kugelkopf-Mutter (kurz)
Ecrou-connecteur à rotule (court)
9808012



BM14 ×2 マウントネジ
Mount screw
Befestigungsschraube
Vis de montage
9805886

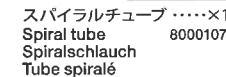

BM21 スパイラルチューブ×1
Spiral tube 8000107
Spiralschlauch
Tube spiralé

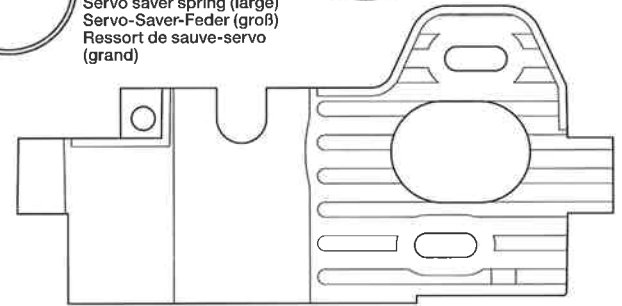

BM21 ×1 モーターマウント
Motor mount
Motor-Lager
Support-moteur
5405046

シャフト袋詰 9400671 Shaft bag Achse-Beutel Sachet d'axes

BS1 ×2 3×48.5mmシャフト
Shaft
Achse
Axe
9805681

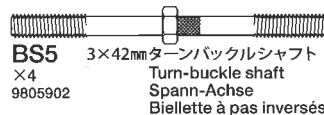

BS5 ×4 3×42mmターンバックルシャフト
Turn-buckle shaft
Spann-Achse
Biellette à pas inversés
9805902

BS2 ×2 3×46mmシャフト
Shaft
Achse
Axe
51093

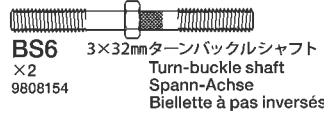

BS6 ×2 3×32mmターンバックルシャフト
Turn-buckle shaft
Spann-Achse
Biellette à pas inversés
9808154

BS3 ×4 2.6×27mmシャフト
Shaft
Achse
Axe
9804301

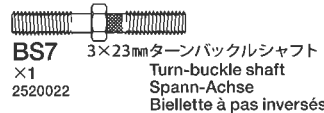

BS7 ×1 3×23mmターンバックルシャフト
Turn-buckle shaft
Spann-Achse
Biellette à pas inversés
2520022

BS4 ×4 2×9.8mmシャフト
Shaft
Achse
Axe
9805776



BS8 ×2 六角ハブ
Hex hub
Sechskant-Nabe
Entraînement hexagonal
9804313



BS9 ×2 リヤアクスルワッシャー
Rear axle washer
Hintere Beilagscheibe der Achse
Rondelle d'axe arrière
9804305



BS10 ×4 4mmフランジロックナット
Flange lock nut
Sicherungsmutter
Ecrou nylstop à flasque
9805557

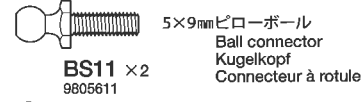

BS11 ×2 5×9mmピローボール
Ball connector
Kugelkopf
Connecteur à rotule
9805611

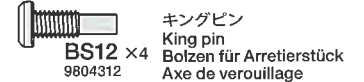

BS12 ×4 キングピン
King pin
Bolzen für Arretierstück
Axe de verouillage
9804312



BS13 ×2 ホイールアクスル (短)
Wheel axle (short)
Rad-Achse (kurz)
Axe de roue (court)
9808152

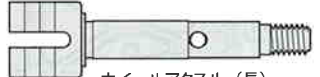

BS14 ×2 ホイールアクスル (長)
Wheel axle (long)
Rad-Achse (lang)
Axe de roue (long)
9808153



BS15 ×2 ドライブシャフト (短)
Drive shaft (short)
Antriebswelle (kurz)
Arbre d'entraînement (court)
51317



BS16 ×2 ドライブシャフト (長)
Drive shaft (long)
Antriebswelle (lang)
Arbre d'entraînement (long)
51316

ダンパー袋詰 9400672 Damper parts bag Dämpferteile-Beutel Sachet de pièces d'amortisseurs

BD1 ×8 2mmEリング
E-Ring
Circlip
50588

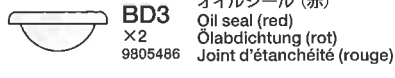

BD3 ×2 オイルシール (赤)
Oil seal (red)
Ölabdichtung (rot)
Joint d'étanchéité (rouge)
9805486

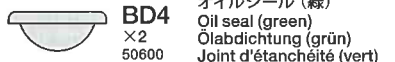

BD4 ×2 オイルシール (緑)
Oil seal (green)
Ölabdichtung (grün)
Joint d'étanchéité (vert)
50600

BD2 ×2 ピストンロッド (短)
Piston rod (short)
Kolbenstange (kurz)
Axe de piston (court)
50601



BD5 ×2 ピストンロッド (長)
Piston rod (long)
Kolbenstange (lang)
Axe de piston (long)
9805917



BD6 ×8 3mmOリング (赤)
O-ring (red)
O-Ring (rot)
Joint torique (rouge)
50597



BD7 ×2 53927 コイルスプリング (短)
Coil spring (short)
Spiralfeder (kurz)
Ressort hélicoïdal (court)



BD8 ×2 53927 コイルスプリング (長)
Coil spring (long)
Spiralfeder (lang)
Ressort hélicoïdal (long)

PARTS

★金具部品は少し多目に入っています。予備、セッティング用として使ってください。
 ★Extra screws and nuts are included. Use them as spares.
 ★Es liegen zusätzliche Schrauben und -muttern bei. Als Ersatzteile verwenden.
 ★Des vis et des écrous supplémentaires sont inclus. Les utiliser comme pièces de rechange.

ベアリング袋詰

Ball bearing bag
Kugellager-Beutel
Sachet de roulements à billes

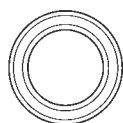

BE1 ×4
53126

1510ベアリング
Ball bearing
Kugellager
Roulement à billes



BE2 ×8
51239

1050ベアリング
Ball bearing
Kugellager
Roulement à billes



BE3 ×4
53030 850ベアリング
Ball bearing
Kugellager
Roulement à billes



BE4 ×2
9808022 730ベアリング
Ball bearing
Kugellager
Roulement à billes



BE5 ×2
9805672 840ベアリング
Ball bearing
Kugellager
Roulement à billes



BE6 ×4
9805185 850メタル
Metal bearing
Metall-Lager
Palier en métal

シム袋詰

Shim bag
Scheibe-Beutel
Sachet de cale

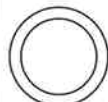

BH1 ×10
53588

10×0.2mmシム
Shim
Scheibe
Cale



BH2 ×10
53587

5×0.2mmシム
Shim
Scheibe
Cale



BH3 ×10
53586

4×0.2mmシム
Shim
Scheibe
Cale



BH4 ×10
53585

3×0.2mmシム
Shim
Scheibe
Cale

ビス袋詰 B

Screw bag B
Schraubenbeutel B
Sachet de vis B



BB1 ×2
9804202

3×23mm皿ビス
Screw
Schraube
Vis



BB2 ×1
9808156

3×16mm皿ビス
Screw
Schraube
Vis



BB3 ×1
9808155

3×14mm皿ビス
Screw
Schraube
Vis



BB4 ×2
9805977

3×12mm皿ビス
Screw
Schraube
Vis



BB5 ×5
9805696

3×8mm皿ビス
Screw
Schraube
Vis



BB6 ×5
9804286

3×6mm皿ビス
Screw
Schraube
Vis

ビス袋詰 C

Screw bag C
Schraubenbeutel C
Sachet de vis C



BC1 ×18
9805898

3×12mm丸ビス
Screw
Schraube
Vis



BC2 ×1
9805636

3×6mm丸ビス
Screw
Schraube
Vis

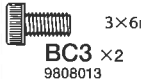

BC3 ×2
9808013

3×6mmキャップスクリュー
Cap screw
Zylinderkopfschraube
Vis à tête cylindrique



BC4 ×1

3×6mmフラットビス
Screw
Schraube
Vis



BC5 ×1
50577

3×10mmタッピングビス
Tapping screw
Schneidschraube
Vis taraudeuse



BC6 ×1
50575

2.6×10mmタッピングビス
Tapping screw
Schneidschraube
Vis taraudeuse



BC7 ×5
9805777

3×2.5mmイモネジ
Grub screw
Madenschraube
Vis pointeau

ボールデフ部品袋詰

Ball differential bag
Kugeldifferential-Beutel
Sachet de différentiels à billes



BG1 ×2
9949350

2mmロックナット
Lock nut
Sicherungsmutter
Ecrou nylstop



BG2 ×2
9949300

620スラストベアリング
Ball thrust bearing
Druckkugellager
Butée à billes



BG3 ×2
9949299

デフスプリング
Diff spring
Differentialfeder
Ressort de diff

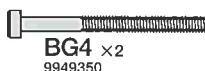

BG4 ×2
9949350

2×25mmキャップスクリュー
Cap screw
Zylinderkopfschraube
Vis à tête cylindrique

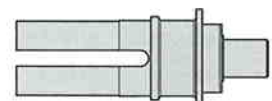

BG5 ×2 51315
デフジョイント (長)
Diff joint (long)
Differential-Gelenk (lang)
Accouplement de différentiel (long)

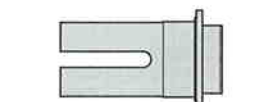

BG6 ×2 51315
デフジョイント (短)
Diff joint (short)
Differential-Gelenk (kurz)
Accouplement de différentiel (court)

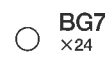

BG7 ×24

3mmスチールボール
Ball
Kugel
Bille

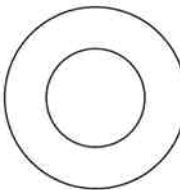

BG8 ×4
51287

デフプレート
Diff plate
Differentialplatte
Plaque de diff

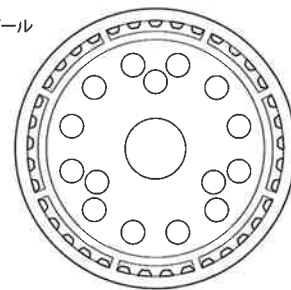

BG9 ×2
53988

37Tボールデフプーリー
37T Ball differential pulley
37Z Kugeldifferential-Antriebsrad
Poulie de diff. à billes 37 dts

工具袋詰

Tool bag
Werkzeug-Beutel
Sachet d'outillage

ダンパーオイル (#900) ×1
Damper oil
Dämpfer-Öl
Huile pour amortisseurs 53445



BT1 ×12
51283

5mmアジャスターL
Adjuster
Einstellstück
Chape à rotule



BT2 ×2
50875

5mmアジャスター
Adjuster
Einstellstück
Chape à rotule



BT3 ×1

アンテナキャップ
Antenna cap
Antennenkappe
Capuchon d'antenne



アンチウェアグリス ×1
Anti-wear grease 53439
Verschleiß minderndes Fett
Graisse anti-usure

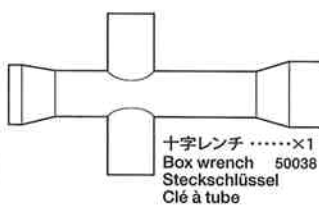

十字レンチ ×1
Box wrench 50038
Steckschlüssel
Clé à tube

六角棒レンチ (2.5mm L) ×1 2990050
Hex wrench (2.5mm L)
Imbusschlüssel (2,5mm L)
Clé Allen (2,5mm L)

六角棒レンチ (2mm) ×1 2990027
Hex wrench (2mm)
Imbusschlüssel (2mm)
Clé Allen (2mm)

六角棒レンチ (1.5mm) ×1 50038
Hex wrench (1.5mm)
Imbusschlüssel (1,5mm)
Clé Allen (1,5mm)



モリブデングリス ×1
Molybdenum grease 87022
Molybdänfett
Graisse de molybdène



ボールデフグリス ×1
Ball Diff Grease 53042
Fett für Kugeldifferential
Graisse pour différentiel à billes

ナイロンバンド ×3
Nylon band 50595
Nylonband
Collier en nylon

アルミガラステープ ×1
Aluminum glass tape
Aluminium-Glasfaser Kleband
Bande renforcée aluminium

両面テープ (黒・20×120mm) ×1
Double-sided tape (black) 50171
Doppelklebeband (schwarz)
Adhésif double face (noir)

スポンジテープ (20×100mm) ×2
Sponge tape
Schaumgummi-Kleband
Bande mousse

AFTER MARKET SERVICE CARD

When purchasing Tamiya replacement parts, please take or send this form to your local Tamiya dealer so that the parts required can be correctly identified and supplied. Please note that specifications, availability and price are subject to change without notice.

KUNDENNACHBETREUUNGS-KARTE

Wenn Sie TAMIYA-Ersatzteile kaufen möchten, nehmen Sie bitte zur Unterstützung dieses Formular mit zu Ihrem örtlichen Fachhändler. Bezüglich der Angaben, der Lagerhaltung der Artikel und der Preise sind Änderungen vorbehalten.

SERVICE APRES-VENTE
LISTE DE PIECES DETACHEES

Afin de vous permettre de vous procurer des pièces de rechange Tamiya, amenez cette liste à votre point de vente Tamiya qui ne manquera pas de vous renseigner. Veuillez noter que les caractéristiques, disponibilité et prix peuvent changer sans avis préalable.

PARTS CODE

Table with 2 columns: Part Number, Part Name. Includes items like Chassis, A Parts (A1-A16), DB01 B Parts, etc.

Table with 2 columns: Part Number, Part Name. Includes items like 2.6x10mm Tapping Screw, 3x2.5mm Grub Screw, etc.

Table with 2 columns: Part Number, Part Name. Includes items like Center Pulley (18T), Motor Mount, 3x4.5mm Shaft, etc.

部品請求について
For Japanese use only!
★部品のなくしたり、こわした方は、このステッカーが貼られたカスタマーサービス取次店でご注文いただけます。

①郵便振替のご利用方法
②代金引換のご利用方法
③タミヤカードのご利用方法

《住所》 〒422-8610 静岡県駿河区恩田原3-7
株式会社タミヤ カスタマーサービス係
《お問い合わせ電話番号》 静岡 054-283-0003

1/10RC 4WDレーシングバギー
DB01シャーシ
★価格は予告なく変更となる場合があります。
部品名 価格 部品コード
シャーシ.....1,400円 9335492

Table with 2 columns: Part Name, Price. Includes items like リアアクスルワッシャー (2個) 260円, 5x9mmピローボール (5個) 350円, etc.

Table with 2 columns: Part Name, Price. Includes items like W/パーツ (2枚) 500円・140円, X/パーツ (2枚) 500円・140円, etc.